

# Development of Low-Floor Electric Community Bus For Public Transportation and its Demonstration in Toyama City

Shigeru Motohira\*<sup>1</sup>

Hiroki Morino\*<sup>2</sup>

Yasuhiro Matsumoto\*<sup>3</sup>

Masatoshi Fukuda\*<sup>4</sup>

Hideo Ohmoto\*<sup>4</sup>

## 1. Introduction

In Japan, transportation makes up 20% of total carbon dioxide emissions, and the introduction of electric vehicles (EVs) has begun with the aims of saving energy and reducing carbon dioxide emissions.

Furthermore, as a single bus can transport many people, buses produce low carbon dioxide emissions per person in comparison with cars. If diesel-engine buses are replaced with EVs, they should be an effective means of reducing carbon dioxide emissions.

In recent years, community buses have been introduced nationwide to ensure the mobility of senior citizens. Although we developed an electric bus previously,<sup>1),2)</sup> it was not applied as a means of public transport for passengers with wheelchairs.

Therefore, we have adopted a low-floor vehicle as the base vehicle in our latest project, and the bus shown Fig.1 was developed.

The electric bus was substituted for a diesel-engine



Fig.1 Low-floor electric community bus

bus on an existing route, and the demonstration was carried out to examine whether the electric bus was suitable for use as a community vehicle by evaluating its energy consumption and environmental performance.

## 2. Low-Floor Electric Community Bus

The bus that we modified was a conventional low-floor diesel engine bus. The base bus has a riding capacity in total of 31; 14 seating, 16 standing and a driver.

What we planned to secure seating capacity were; to utilize the base vehicle transmission, and, to limit the interior modification by assembling all electrical devices into engine compartment. Fig.2 shows the power system of the electric bus. The remodeling method is shown as follows.

### (1) Motor

Utilizing the base vehicle transmission forced us to use the original gearbox, but by using a motor that generates a torque equal to that generated by the original diesel engine, we managed to install relatively smaller motor that matches the reduction ratio.

The motor's volume was measured 1/3 by comparison with that of the engine, and this reduction in volume allowed us an extra space for battery installation. Also, the fuel tank space emptied by electrifying the vehicle provided us further space for battery.

### (2) Power steering

Power steering helps to reduce the force required for the driver to steer the vehicle, and this is driven by a hydraulic pump powered by the engine and the hydraulic pressure assists the steering force. We achieved this function by using a motor to power the hydraulic pump. Hydraulic pressure line uses original parts, and we installed a motor / hydraulic pump

\*1 Jyogajji Electric Power Engineering Dept., Toyama Branch

\*2 Corporate Planning Dept.

\*3 Engineering Research & Development Center

\*4 Tokyo R&D Co., Ltd.

integrated unit. We selected motor and power of approx 2kW, and the choice was an induction motor with general purpose industrial inverter.

### (3) Electrical water heater

The heater originally uses the engine coolant, but in case of EV, we cannot expect to use the heat generated by the engine, therefore we decided to use electric water heater. To equalize the performance of this heater with that of the base vehicle's heater, we installed 3 units of 4kW model. One is for the driver's seat which serves for both; a heater for the driver's seat and a defroster for the front windshield. Two more units are installed in the cabin. Each of these 3 units is capable of heating water independently, and we devised a measure to reduce power consumption by applying individual switches to allow each heater to work independently according to needs in the cabin area.

### (4) Installation of Lithium-Ion battery

We paid extra attention to rear axial load and height of gravitational center in the detail evaluation of Lithium-Ion battery installation.

To limit the height of the battery's center of gravity, we first decided the battery location, and then laid out other devices in the residing space.

These battery modules are forced-air cooled type

having a built-in cooling pack. Cooling air is taken in from cabin and blown out into the engine compartment. The reason to take in air from cabin is to avoid taking in heated air into the pack during summer time.

Fig.3 shows the battery modules, the motor and the inverter installed in the bus. Two battery modules were set among the passenger seating, one battery was placed where the fuel tank was originally located and another battery module was set in the engine compartment.

### (5) Completed vehicle

Table 1 shows the specifications of the bus. The capacity is 29 passengers and the seating capacity is 13 seats and the battery type is lithium-ion. The range of the bus when running in an urban area is 40km on a full charge.

Because the bus has a low floor, senior citizens and wheelchair users can easily get on and off. Fig.4 shows a wheelchair user getting off the bus during the demonstration.

Fig.5 shows the connector used for charging the bus. The bus has two connecting plugs and can be charged using one or two battery chargers with 50kW power. Using two battery chargers, the maximum charging power is 100kW and the batteries can be charged in about 30 minutes.

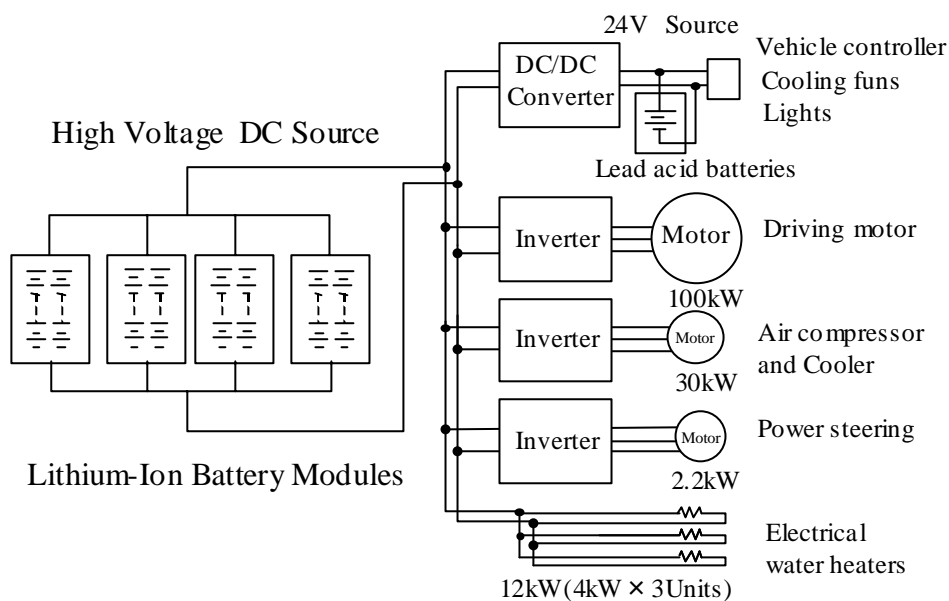

Fig.2 System configuration of the bus

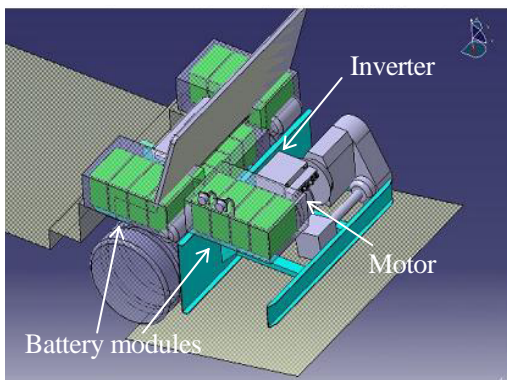

Fig.3 Battery modules, Motor, and Inverter installed in the bus



Fig.4 Wheelchair user

Table 1 Specifications of the bus

Length (mm)	6,990
Width (mm)	2,080
Height (mm)	3,100
Empty mass (kg)	5,980
Number of seats	13
Number of passengers	29
Motor type	3-phase Brushless PM
Maximum motor power (kW)	100
Maximum torque (N·m)	550 (0- 1,500rpm)
Maximum speed (km/h)	84
Battery type	Lithium-ion
Available battery capacity (kWh)	40
Duration (km)	40



Fig.5 Connector used for charging the bus

### 3. Demonstration

The bus was demonstrated around the center of Toyama City from March 9 to 21, 2010.

Fig.6 shows a map of the route. The bus followed a relatively flat circular route of distance 7.2km. The number of bus stops on the route was 27 and the driving time was 40 minutes per circuit.

In the demonstration, an integrated wattmeter was installed on the primary side of the battery chargers for the electric bus. The batteries were recharged after one operation, and the charged energy required for the operation was measured. Also, the voltage, current of the battery modules and the speed of the bus were recorded using a data logger in the electric bus.

Fig.7 shows the bus during the demonstration. The bus ran two circuits of the route then it was charged at the charging station, which was 1.5km from the start of

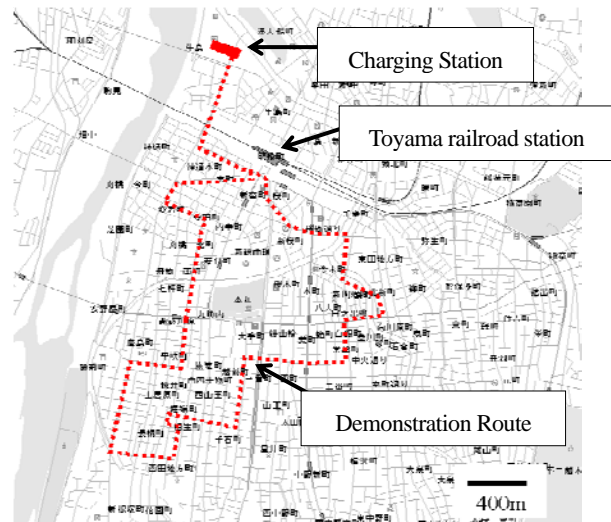

Fig.6 Map of the demonstration route in Toyama City

the route. This demonstration was repeated three to four times a day for 14 days.

During the 86 circuits of the demonstration, a total of 1,110 passengers used the bus. The average number of passengers was 13 people and the total running distance was 776km.



Fig.7 Electric bus during demonstration

#### 4. Results and Discussion

##### (1) Running performance

Fig.8 shows the relationships between discharge energy and current during a part of the demonstration. Electrical water heaters for air conditioning were not used at the time. The discharge energy was 17.8kWh and the energy consumption rate was 1.0kWh/km.

On the other hand, Fig.9 shows the relationship between discharge energy and current when air conditioning was used. The energy consumption rate in this case was 1.4kWh/km. Thus, it was obviously increased by the use of air conditioning.

Fig.10 shows the relationship between external temperature and the energy consumption rate. The energy consumption rate significantly varied with the external temperature owing to the variability of the power consumed by the electrical water heaters. The average energy consumption rate during the demonstration was 1.3kWh/km.

##### (2) Reduction of carbon dioxide emissions

From the average fuel consumption of diesel- engine buses operating along the same route during the month of the March 2010, carbon dioxide emissions were calculated. The results are shown in Table 2.

From the results, we concluded that the quantity of carbon dioxide emissions can be reduced by 35% using the electric bus in comparison with that of a conventional diesel-engine bus.

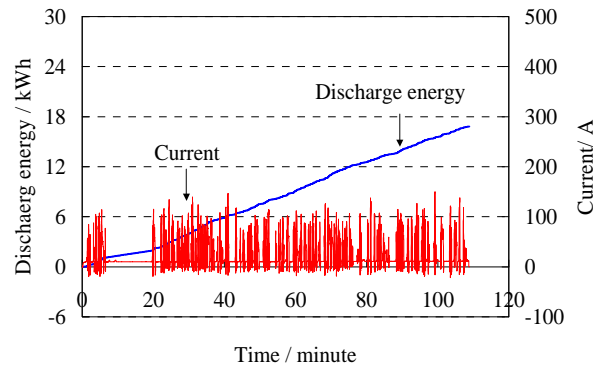

Fig. 8 Typical current and discharge energy curve during demonstration. Air conditioning was used

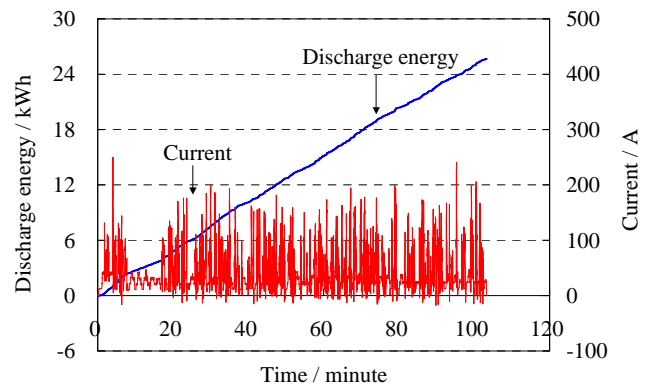

Fig. 9 Typical current and discharge energy curve during demonstration. Air conditioning was used

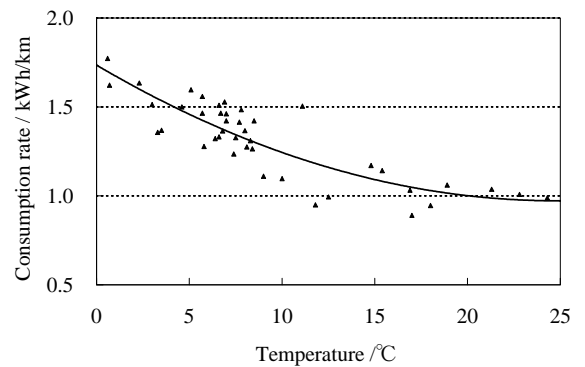

Fig.10 Relationship between temperature and energy consumption rate

Table 2 CO<sub>2</sub> emission effects of electric and diesel-engine buses

Electric bus	Value
Energy consumption rate (include charger) (kWh/km)	1.6
CO <sub>2</sub> emission coefficient (kg- CO <sub>2</sub> /kWh)	0.32
CO <sub>2</sub> emission (kg- CO <sub>2</sub> /km)	0.51
Diesel engine bus	Value
Fuel consumption (km/L)	3.3
CO <sub>2</sub> emission coefficient (kg- CO <sub>2</sub> /L)	2.6
CO <sub>2</sub> emission (kg- CO <sub>2</sub> /km)	0.79
Reduction of CO <sub>2</sub> emission (%)	35

## 5. Conclusions

A low-floor electric bus was developed, and its feasibility was shown in the 14 days demonstration in Toyama city, during which it ran along a community bus route.

According to the result of the demonstration, the quantity of carbon dioxide emissions can be reduced by 35% using our proposed bus in comparison with that of a conventional diesel-engine bus.

## Acknowledgement

This work is partly supported by the Ministry of Economy, Trade and Industry.

## References

- [1] Ozawa, K. Fujii, M. Uede, N. Ohnuma, T. Futakuchi, T. Watanabe, and H. Morino, *WEVA J.*, **1**, 165 (2007).
- [2] Uede, H. Ozawa, and T. Ogihara, *Proc. of the 2010 Japan Industry Applications Society Conference*, **1**, 78 (2010).

(本論文は、EVS25 World Electric Vehicle Journal Vol.4 号(2011)「Development of Low-Floor Electric Community Bus For Public Transportation and its Demonstration in Toyama City」より、許諾の上転載しております。)